

## EXAMPLES OF APPLICATIONS

The applications of the MiniTec profile system are almost unlimited. This system offers economic solutions for general machinery designs but also for office furniture, partitions, sound proofing walls and boxes, individually constructed workstations and assembly lines, robots, portal systems, and linear guides



Roller conveyor with pneumatic stoppers

Brushing machine for furniture boards

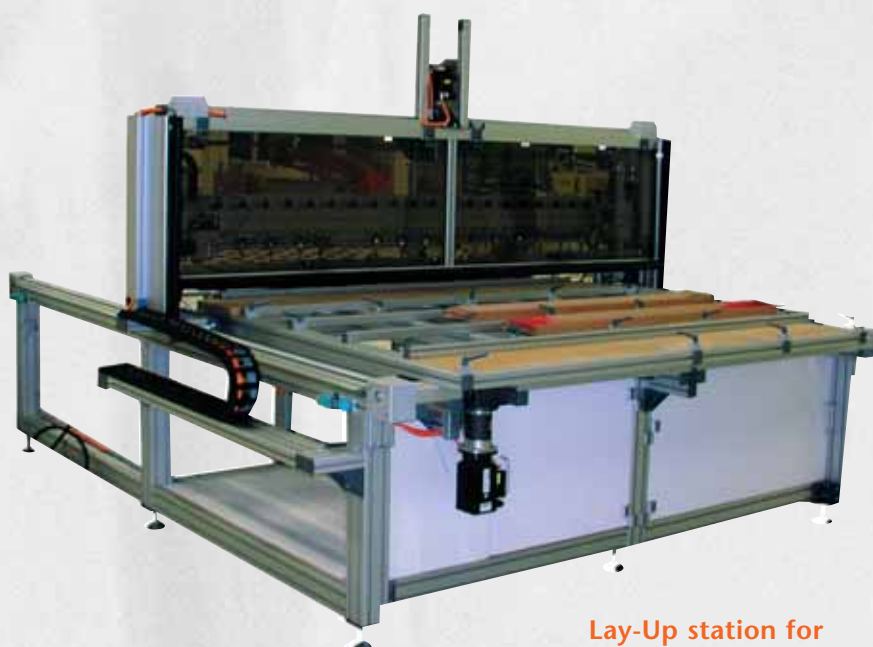

Lay-Up station for solar cells

## EXAMPLES OF APPLICATIONS



Framing of solar-modules

3-D-measuring machine

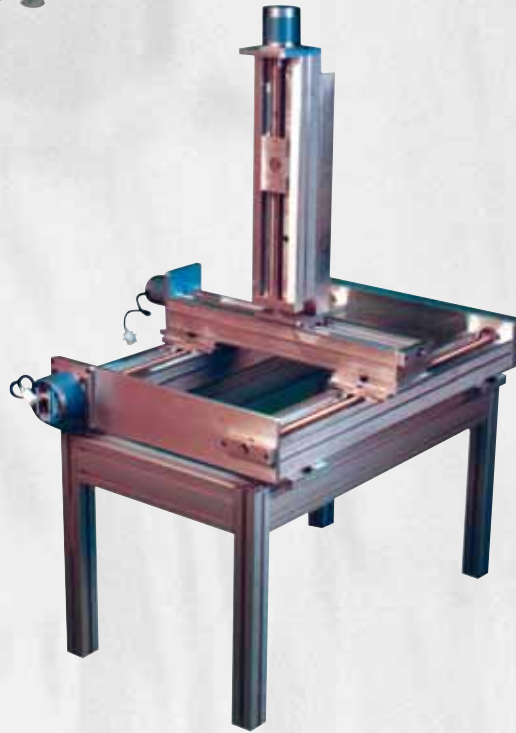

Optical quality inspection

## EXAMPLES OF APPLICATIONS



Packing unit for toothbrushes

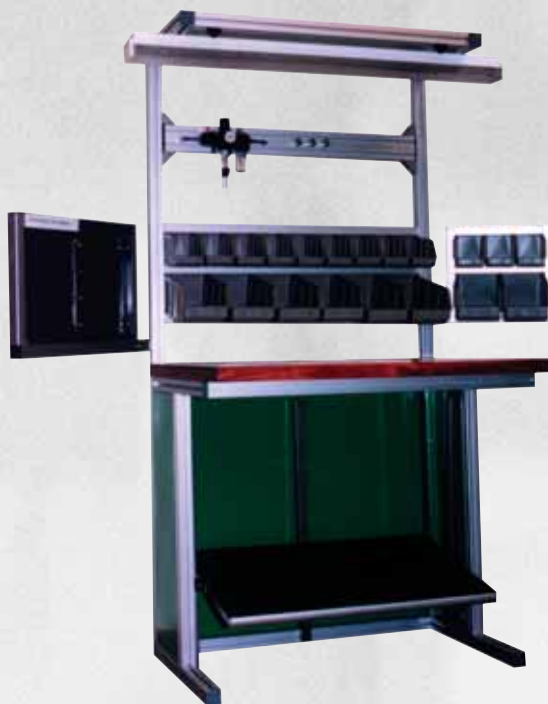

Workstation



System Workstation with customized workpiece trays

## EXAMPLES OF APPLICATIONS



Machine frame with guarding



Automatic glue dispenser



Conveyor with label applicator

## EXAMPLES OF APPLICATIONS



Very slow moving linear guide for environment test lab



Label printer and applikator



Height-adjustable table-top motorized

## EXAMPLES OF APPLICATIONS



Longitudinal stop

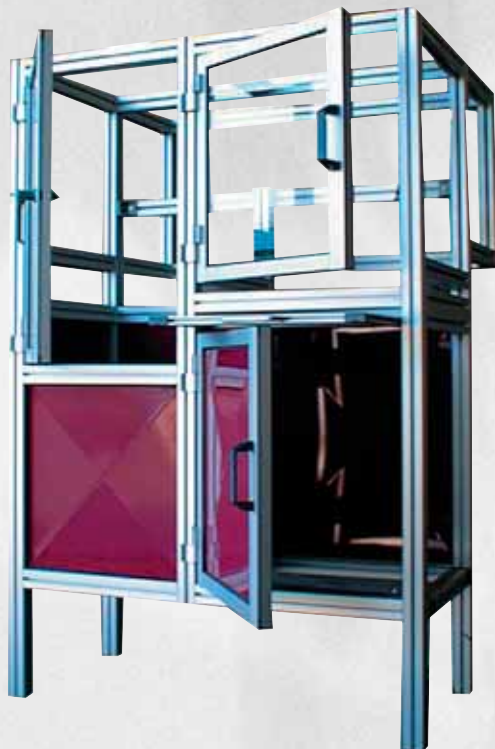

Machine frame



Packingline with roller conveyors

## EXAMPLES OF APPLICATIONS



Optical measuring machine with PC-control



Optical measuring machine with PC-control



Optical measuring machine with PC-control

## EXAMPLES OF APPLICATIONS

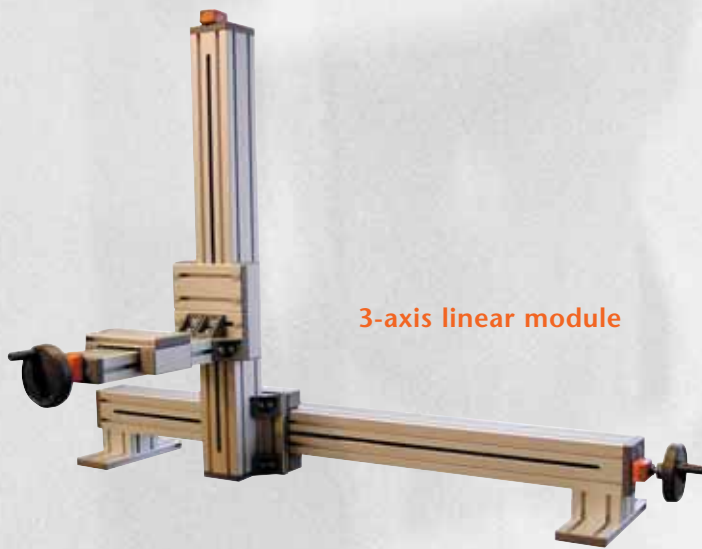

3-axis linear module



Machine frame with special glass screens for high-temperature application

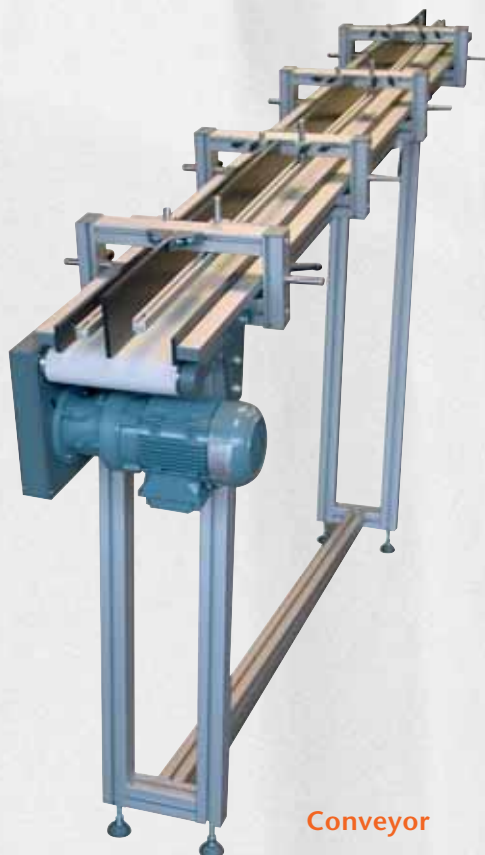

Conveyor

## EXAMPLES OF APPLICATIONS



Transfer system TSG 200

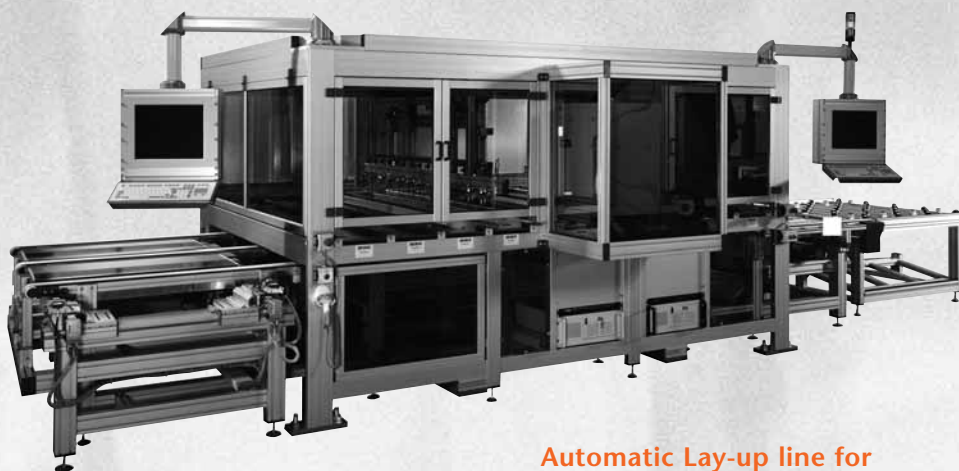

Automatic Lay-up line for solar modules



Workstation

## EXAMPLES OF APPLICATIONS

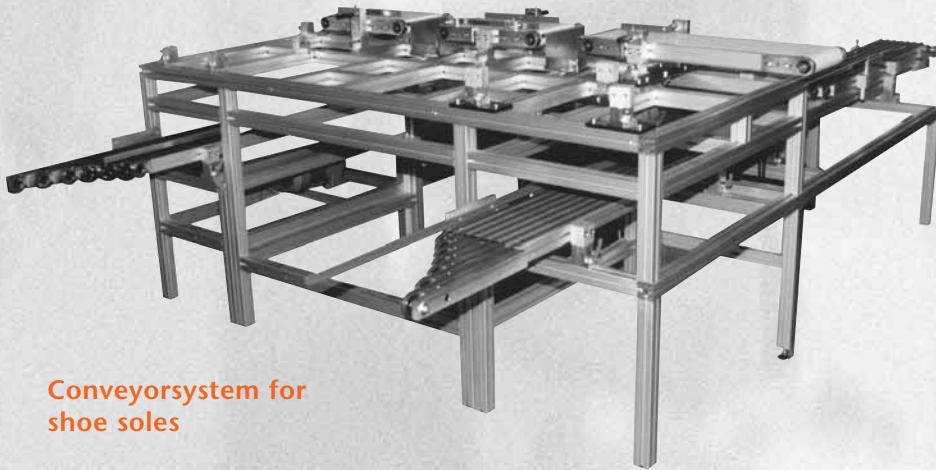

Conveyorsystem for shoe soles

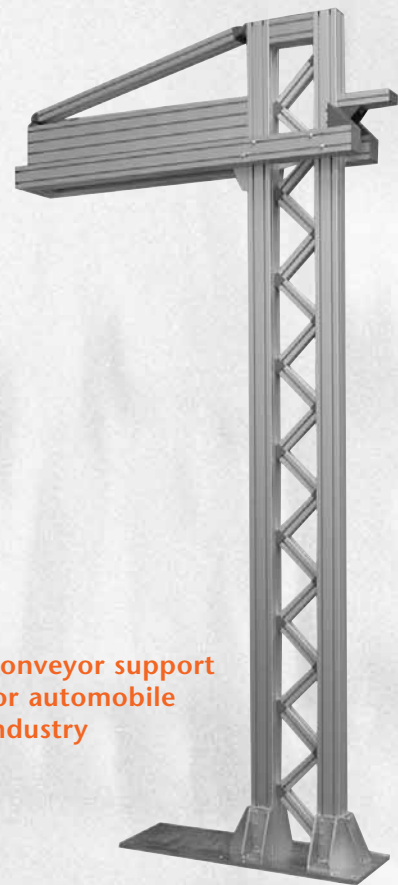

Conveyor support for automobile industry



Welding enclosure

## PROJECT EXAMPLES

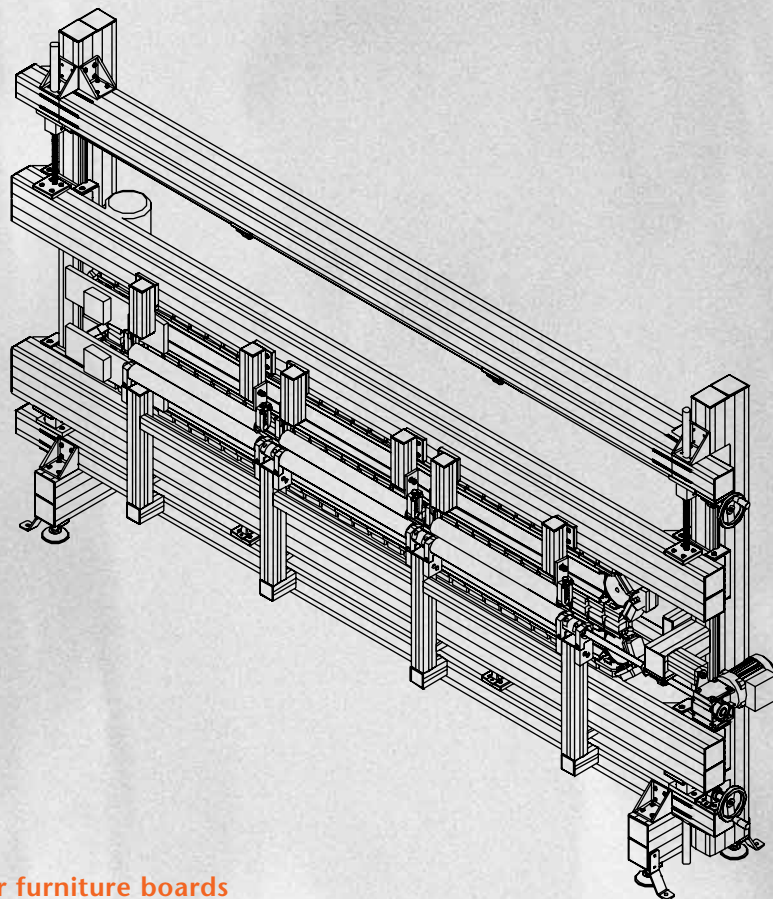

Brushing machine for furniture boards

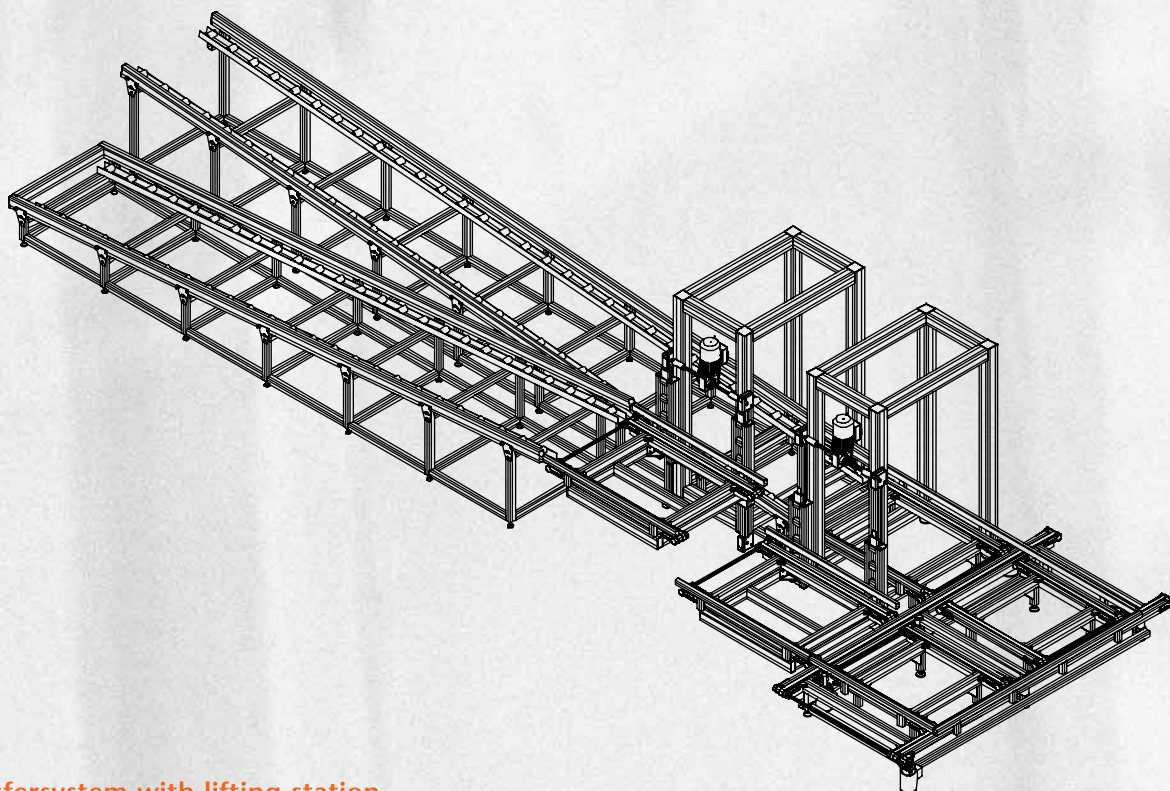

Transfersystem with lifting station

## PROJECT EXAMPLES

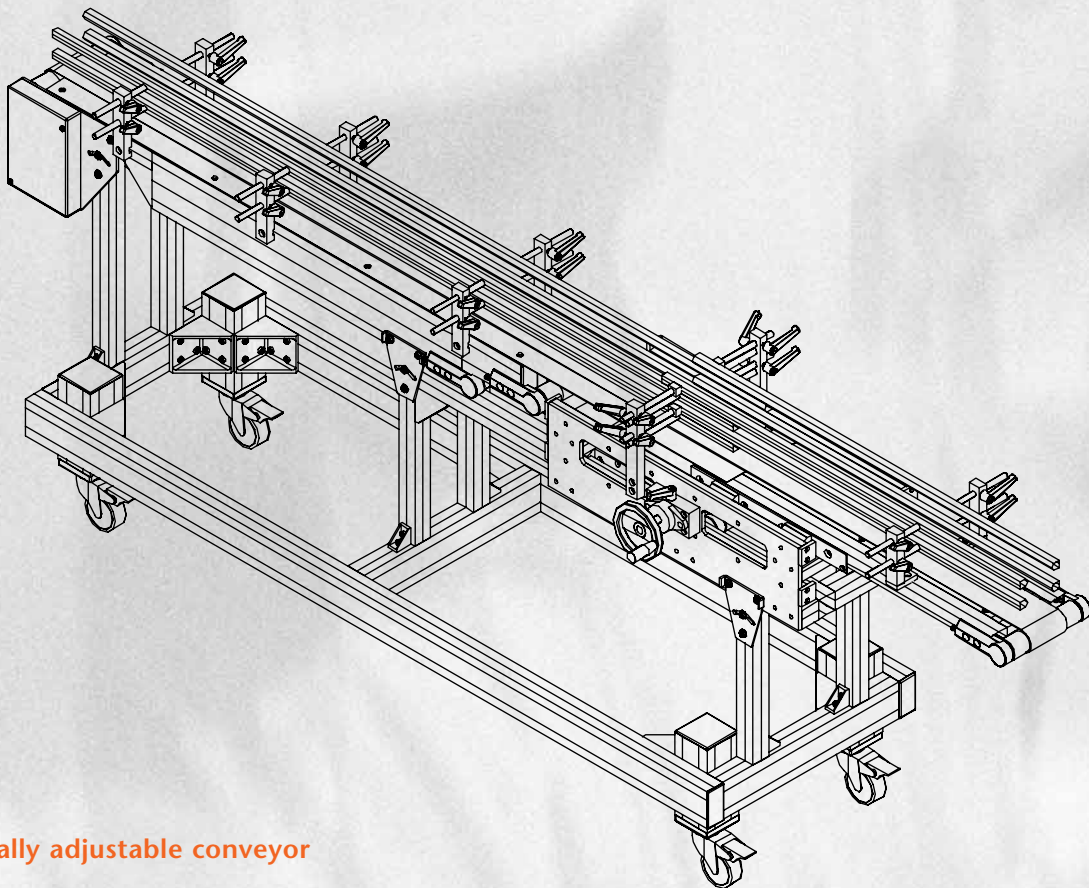

Longitudinally adjustable conveyor

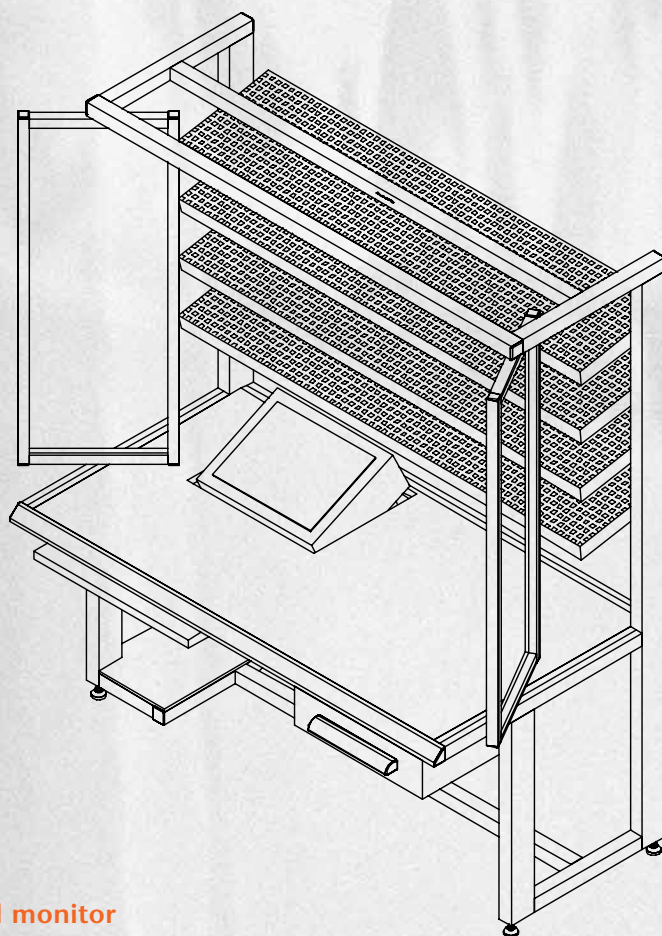

Workstation with hinged monitor