

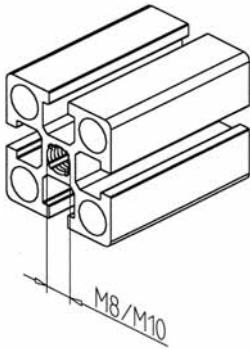

PROCESSING SERVICES

PROCESSING SERVICES

The MiniTec profile system requires minimum of processing. Saw cutting and thread-forming are the essential processes, only in exception cases is drilling required.



Thread M8 M10

Thread M8 x 20
in core bore
for power-lock fastener

Part N° 25.1087/0

Thread M10 x 25
in core bore
for feet

Part N° 25.1088/0

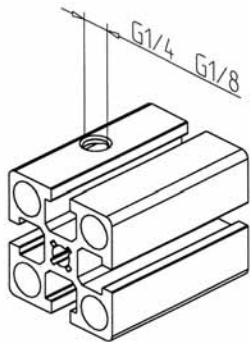

Thread G1/4 G1/8

Thread G 1/4
on profile surface
for pneumatics

Part N° 25.1089/0

Thread G 1/8
on profile surface
for pneumatics

Part N° 25.1090/0

Thread G 1/4
in core bore \varnothing 11,7 mm
for plug, pneumatics

Part N° 25.1091/0

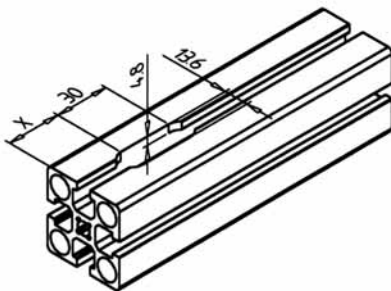

Processing Insertion tide

Through bore \varnothing 7 mm
for screw connection

Part N° 25.1092/0

Insertion tide
on profile surface
for subsequent insertion of
power-lock fastener

Part N° 25.0315/0

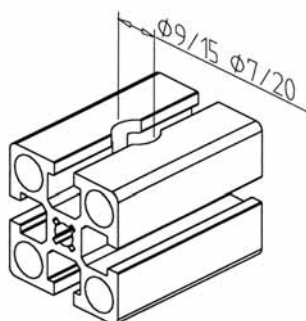

Bore

Bore \varnothing 9 / \varnothing 15
for bolt and butt fastener 15

Part N° 25.1085/0

Bore \varnothing 7 / \varnothing 20
for bolt and butt fastener

Part N° 25.1097/0