

3

TURN-KEY SOLUTIONS



WORKSTATION

Our construction modul "Workstation" of our CADmenu draws fully automatic your individual workstation including correct parts list

CUSTOMISED WORKSTATION COMPONENTS



1. Workbench

A great variety standing and sitting workstations can be designed due to free dimension planning.

2. Swivelling tray

Horizontally and vertically slewable with fixing bracket

3. Springpull with sliding eyelet

For hanging tools in correct position

4. Cross beams

Easy attachment of standard grab containers of all kinds and sizes.

5. Tool box

Attachable to the table base left or right with lockable door. Made of grey sheet steel

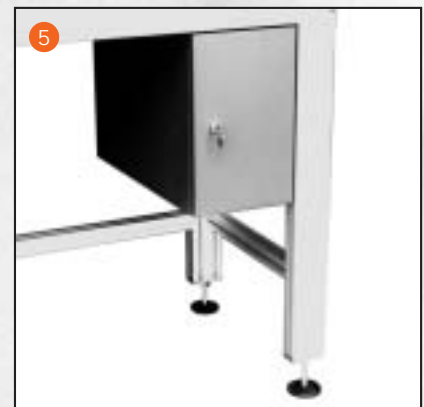
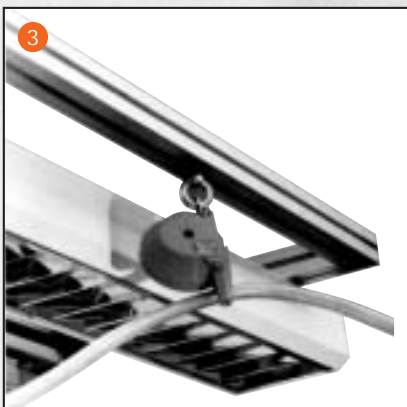
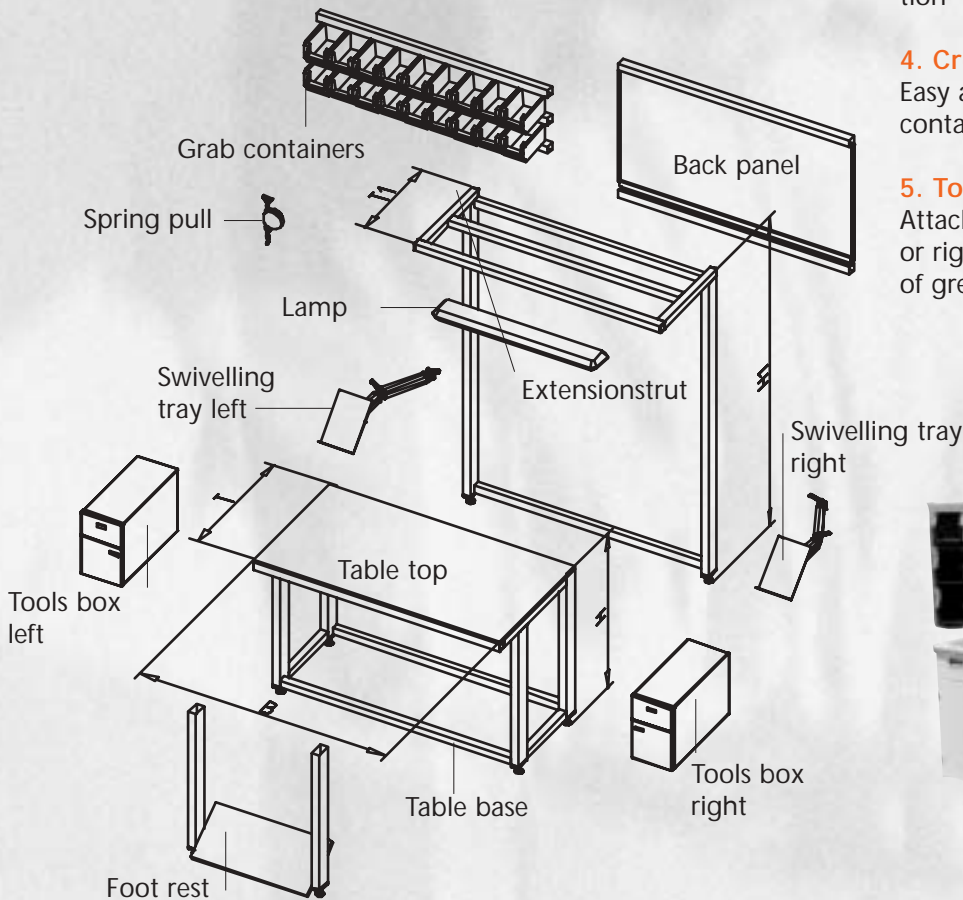

INQUIRY CUSTOMISED WORKTABLE

Dimensions

Width B mm

Height H mm

Depth T mm

Total height H1 mm

Extension strut T1 mm

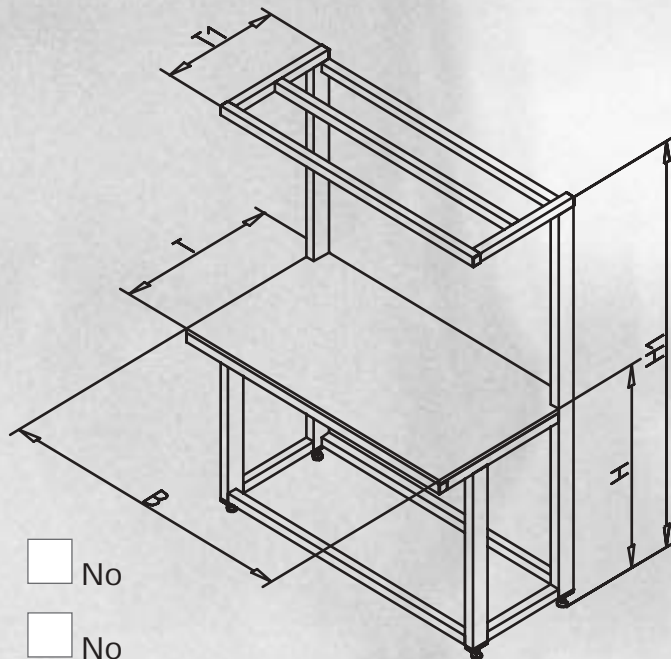

Options

Extension strut Yes No

Foot rest Yes No

Foot rest, adjustable Yes No
 from mm up to mm

Grab containers Yes No Size

Tools box right Yes No

Tools box left Yes No

Pressed air connection Yes No

Lamp Yes No

Back panel Yes No Material

Table top Yes No Material

Spring pull Yes No

Swivelling tray Yes No

Company

Please call me back

Name

Please send me an offer

Phone number

Fax number

SLIDING EYELET

Part N° 21.1769/0

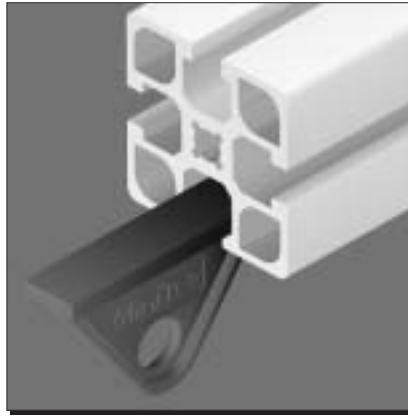
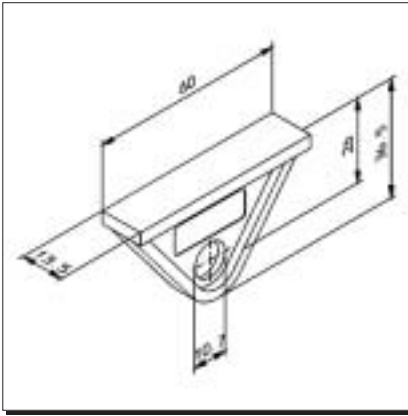

TECHN. DATA/ITEMS SUPPLIED

- ABS, grey
- Suitable for all MniTec profiles

| | | |
|-----------|-------|----|
| Load max. | 100 | N |
| Weight | 0,045 | kg |

APPLICATIONS

- Provisions of tools

ASSEMBLY

- Slip into profile groove
- With snap hook Part N° 21.1699/0

BALANCER

Part N° 29.0111/0

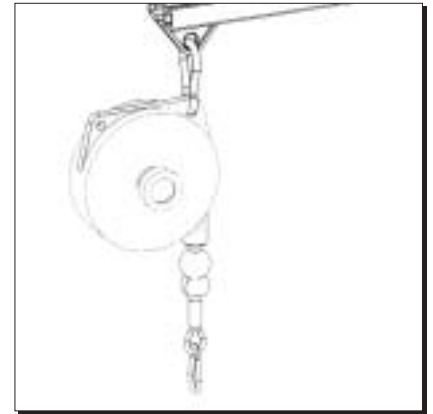
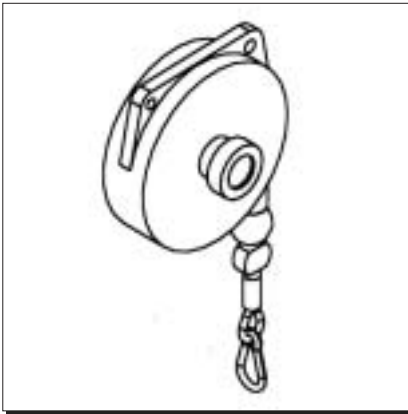

TECHN. DATA/ITEMS SUPPLIED

- For tool weights 2-3 kg
- Higher weights on request

| | | |
|--------|-------|----|
| Weight | 0,750 | kg |
|--------|-------|----|

APPLICATIONS

- Provision of tools

ASSEMBLY

- Insert with snap hook Part N° 21.1699/0 in sliding eyelet Part N° 21.1769/0

TOOLS BAG

Part N° 26.3000/0

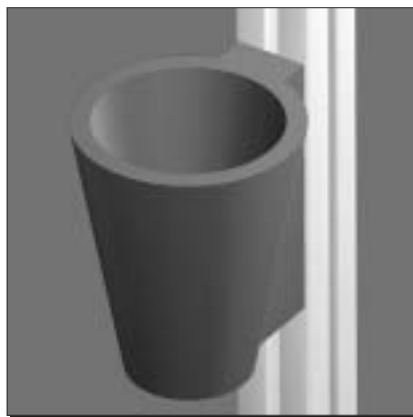
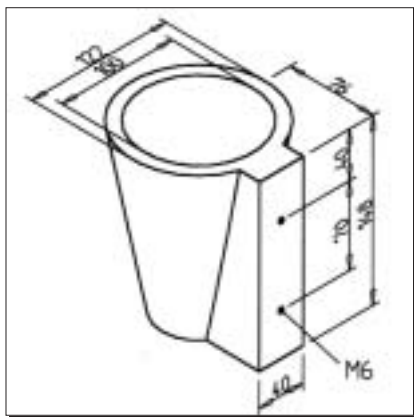

TECHN. DATA/ITEMS SUPPLIED

- Hard rubber, heavy construction, black

Weight 1,050 kg

APPLICATIONS

- Placing at disposed of heavy tools and jigs, e.g. drill, screw-driver, pneumatic tools

ASSEMBLY

- Screw onto profile groove with screws from supply schedule; bore Ø 6,5 mm required

TOOLS BOX (LEFT)

Part N° 29.4712/0

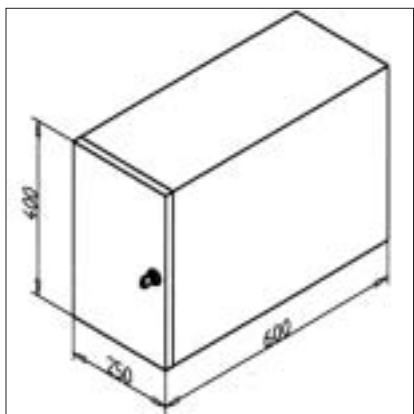

TECHN. DATA/ITEMS SUPPLIED

- Steel sheet, painted RAL 7012

- Measurements: 400 x 250 x 600 mm (H x B x T)

- Safety cylinder lock

Weight 7,850 kg

APPLICATIONS

- For tools, measuring equipment and other equipment used on work tables, work benches or machine

ASSEMBLY

- Fasten at profile groove

TOOLS BOX (RIGHT)

Part N° 29.4712/1

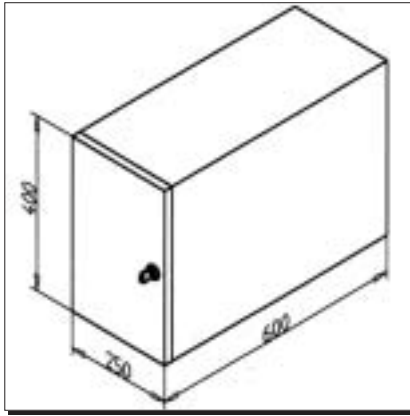

TECHN. DATA/ITEMS SUPPLIED

- Steel sheet, painted RAL 7012
 - Measurements: 400 x 250 x 600 mm (H x B x T)
 - Safety cylinder lock
- Weight 7,850 kg

APPLICATIONS

- For tools, fair equipment and other equipment used on work tables, work benches or machine frames

ASSEMBLY

- Fasten at profile groove

FREE-STANDING FOOTREST

Part N° 29.0117/0

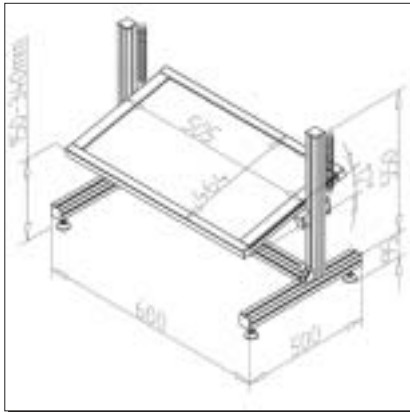

TECHN. DATA/ITEMS SUPPLIED

- Frame: profiles 45 x 45
- Foot-rest: Chip-board, hardcoated
- Assembled, ready for use
- Height adjustable 150 - 340 mm

Weight

APPLICATIONS

- workstations
- Transfersystems
- Assembly lines

ASSEMBLY

- Free-standing
- Beneath
- Workplaces